

IRB 1100

The most compact and fast robot ever



Further expanding ABB's small robot portfolio, IRB 1100 provides 35% increased productivity and up to 10% space savings.

Class-leading performance for high-quality manufacturing

Aimed at increasing manufacturing productivity, IRB 1100 provides up to 35% faster cycle times and best-in-class repeatability for high quality manufacturing. IRB 1100 consistently outperforms similar robots in terms of payload and position repeatability (RP) even when under space constraints. Indeed, IRB 1100 offers the highest payload for a robot of its class.

Compact and small footprint design ensures flexible installation

Compared to the previous generation, the IRB 1100 robot design was optimized with a 10% smaller footprint and over 20% weight reduction for space-efficient installation in diverse environments, such as electronics manufacturing factories.

The small footprint allows multiple robots to be deployed simultaneously in order to collaboratively perform automation operations, enabling more flexible handling for heavy-load operations with complex tools/end effectors.

Powered by ABB's new OmniCore™ controller, IRB 1100 is equipped with advanced motion control capabilities, making it ideal for supporting rapid assembly, pick-and-place, and material handling applications.

Rugged yet compact IP67 rated

The IRB 1100 has IP40 as standard protection and IP67 as option. The entire robot is designed to be IP67 compliant according to IEC 60529 - from base to wrist, which means that the electrical compartments are sealed against water and solid contaminants.

Cleanroom ISO 4

IRB 1100 Cleanroom version provides lower production costs to industries requiring minimal environmental pollutants.

Key benefits

- Offers 35% faster cycle times for increased productivity
- 10% smaller footprint and over 20% weight reduction for easy installation
- The highest payload for a robot of its class
- Equipped with up to 16 I/O connections (C1+C2) for more sophisticated/ complex applications

Main applications

- Assembly & Testing
- Loading & Unloading
- Screw driving
- Rubber insertion
- Polishing, grinding, buffing, deburring and sanding

Specification

Robot version	Reach (m)	Payload (kg)	Armload (kg)
IRB 1100-4/0.475	0.475	4	0.5
IRB 1100-4/0.58	0.58	4	0.5
Number of axes	6		
Protection	Standard IP40. Option IP67.		
Cleanroom	Option ISO 4		
Mounting	Any angle		
Controller	OmniCore C30/C90XT		
Integrated signal and power supply	Up to 16 Signals (C1+C2) on wrist (optional)		
Integrated air supply	4 air on wrist (Max. 6 Bar) (optional)		
Integrated ethernet	One 1000 Base-T ethernet port (optional)		

Performance (according to ISO 9283)

1 kg picking cycle	
25 x 300 x 25 mm	0.42 s

Performance (according to ISO 9283)

	IRB 1100 -4/0.475	IRB 1100 -4/0.58
Pose repeatability, RP	0.01 mm	0.01 mm
Pose stabilization time, PSt (s) within 0.1 mm of the position	0.08	0.19
Path repeatability, RT	0.05 mm	0.05 mm

Technical information

Physical	
Dimensions robot type	160 x 172 mm
Weight IRB 1100-4/0.475	21 kg
Weight IRB 1100-4/0.58	21 kg

Data and dimensions may be changed without notice.

Movement

Axis movement	Working range	Axis max. speed IRB 1100-4/0.475	Axis max. speed IRB 1100-4/0.58
Axis 1 rotation	+230° to -230°	460°/s	460°/s
Axis 2 arm	+113° to -115°	380°/s	360°/s
Axis 3 arm	+55° to -205°	280°/s	280°/s
Axis 4 wrist	+230° to -230°	560°/s	560°/s
Axis 5 bend	+120° to -125°	420°/s	420°/s
Axis 6 turn	+400° to -400°	750°/s	750°/s

Working range, IRB 1100-4/0.475

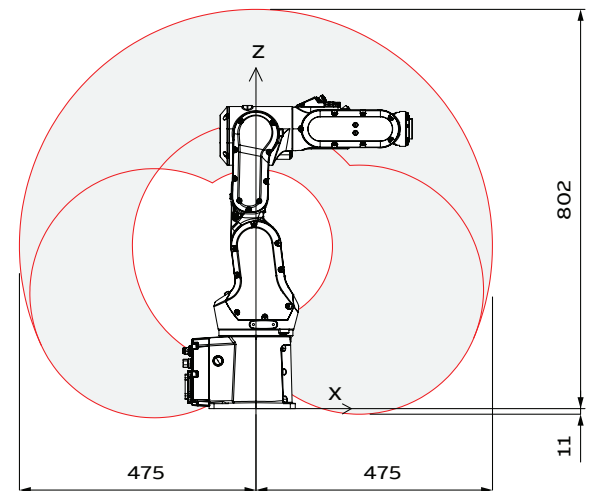

Working range, IRB 1100-4/0.58

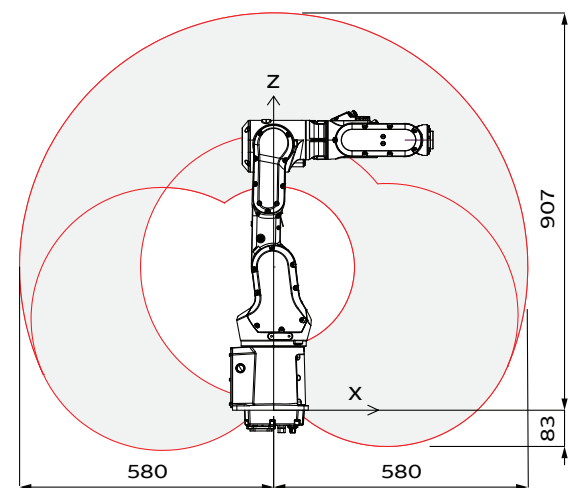

OmniCore™ Controller, FlexPendant & IRB 1100

